



STUNNING SERIES FLOOD LIGHT





PRODUCT PICTURE:



PRODUCT DIMENSION IMAGE (MM):

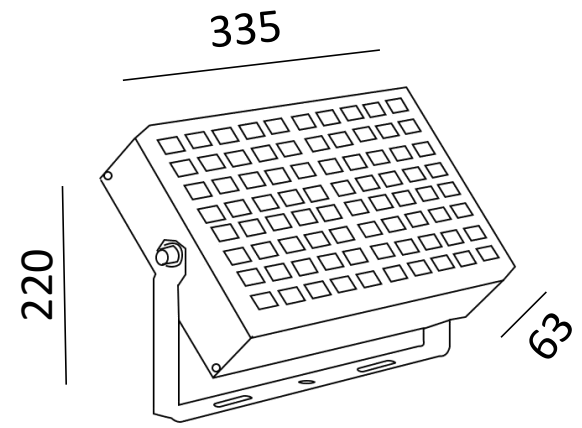
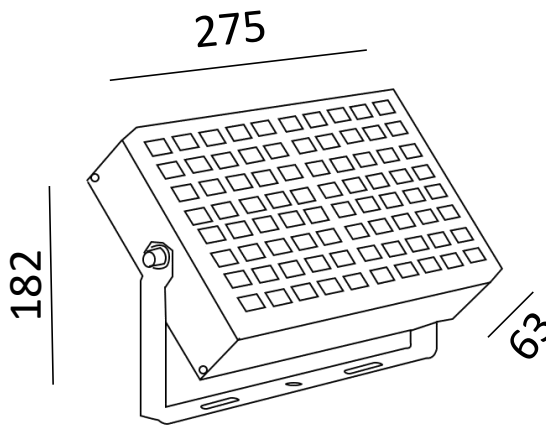
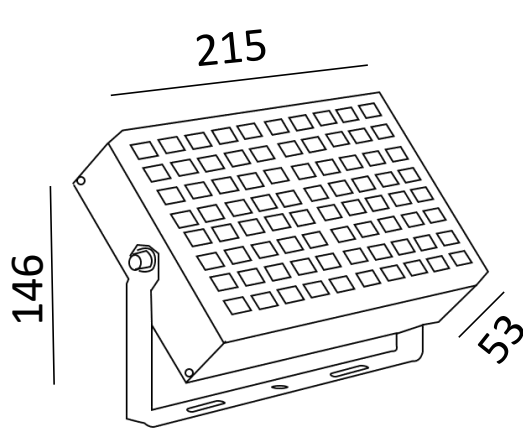



PRODUCT TECHNICAL PARAMETERS

MODEL NO.	CXTGD-50	CXTGD-100	CXTGD-150
LAMP POWER	50W	100W	150W
INPUT VOLTAGE	AC165-265V	AC165-265V	AC165-265V
FREQUENCY RANGE	50-60Hz	50-60Hz	50-60Hz
PF	>0.5	>0.5	>0.5
LEDs	3030	3030	3030
POWER SUPPLY	INTERNAL NON-ISOLATED	INTERNAL NON-ISOLATED	INTERNAL NON-ISOLATED
BEAM ANGLE	120°	120°	120°
CCT	2700-6500K	2700-6500K	2700-6500K
LUMENS	5050LM	10500LM	15750LM
CRI	>70	>70	>70
HOUSING MATERIAL	ALUMINUM	ALUMINUM	ALUMINUM
PRODUCT SIZE (MM)	215*53*H146	275*63*H182	335*63*220
IP RATING	IP65	IP65	IP65
WORKING TEMPERATURE	-20°+50°	-20°+50°	-20°+50°
WARRANTY	3 YEARS	3 YEARS	3 YEARS



PRODUCT CHARACTERISTIC:

- ◆ Utilized high brightness LEDs, delivers bright, uniform light
- ◆ Air convection for heat dissipation, high performance with low cost products
- ◆ Long 50,000 hour rated life reduces maintenance and replacement costs
- ◆ DS floodlight comes with adjustable metal bracket, you can easily install it on the ceiling, walls, ground and other locations by adjusting the different angles, to meet your different needs

APPLICATION:

Buildings, Outdoor Advertising Signs, Landscape, Gardens, and so on.

