

UFO-B HIGH BAY SERIES

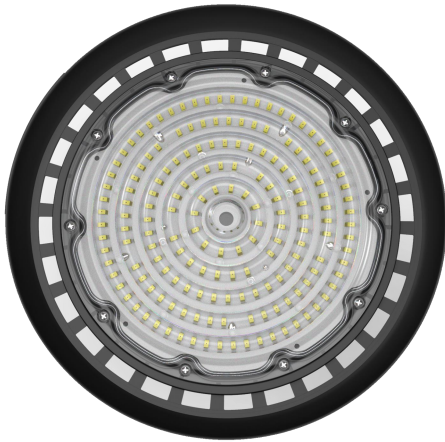



PRODUCT PICTURE:



PRODUCT DIMENSION IMAGE (MM):

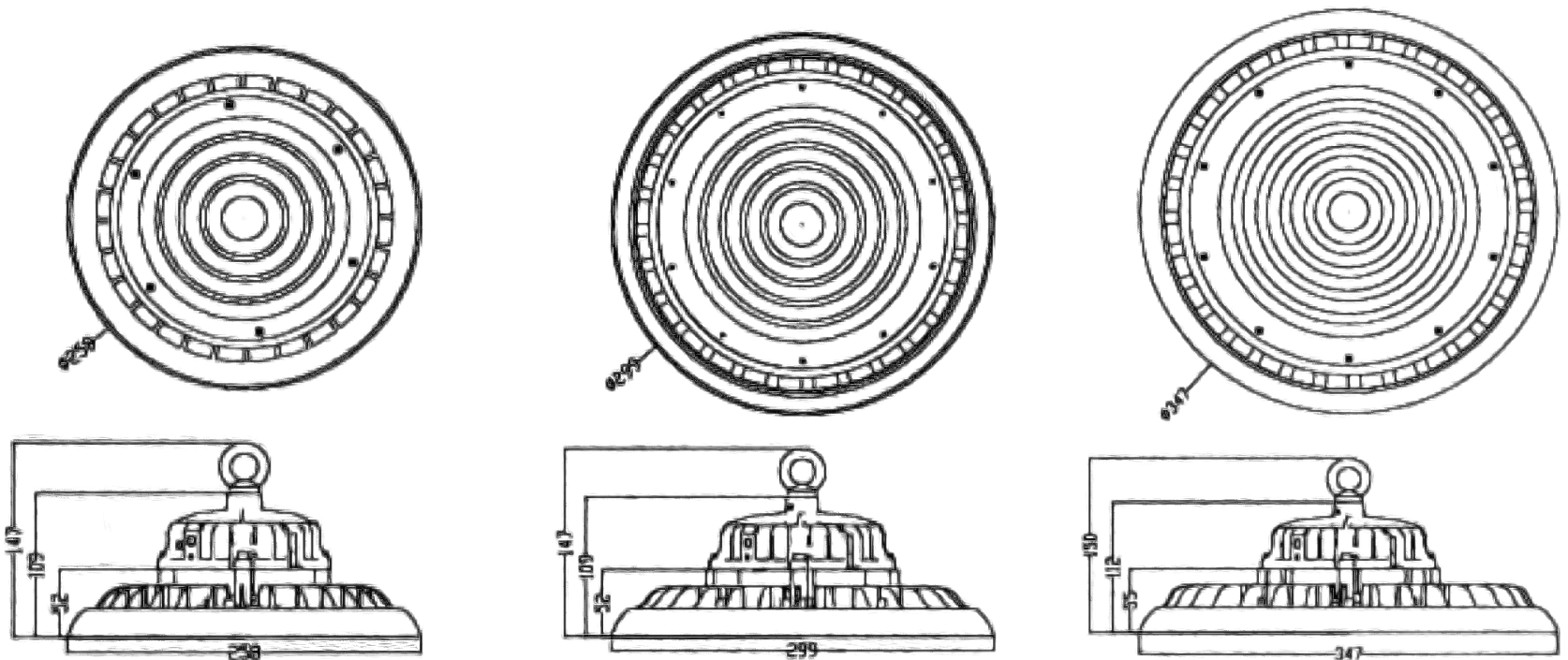



PRODUCT TECHNICAL PARAMETERS

MODEL NO.	UFOGKD-B-100	UFOGKD-B-150	UFOGKDB--200
LAMP POWER	100W	150W	200W
INPUT VOLTAGE	AC85-265V	AC85-265V	AC85-265V
FREQUENCY RANGE	50-60Hz	50-60Hz	50-60Hz
PF	>0.9	>0.9	>0.9
LEDs	3030	3030	3030
POWER SUPPLY	EXTERNAL ISOLATION	EXTERNAL ISOLATION	EXTERNAL ISOLATION
BEAM ANGLE	90°	90°	90°
CCT	2700-6500K	2700-6500K	2700-6500K
LUMENS	10500lm	15750lm	21500lm
CRI	>70	>70	>70
HOUSING MATERIAL	DIE-CASTING ALUMINUM	DIE-CASTING ALUMINUM	DIE-CASTING ALUMINUM
PRODUCT SIZE (MM)	253*111	308*117	354*122
IP RATING	IP65	IP65	IP65
WORKING TEMPERATURE	-20°+50°	-20°+50°	-20°+50°
WARRANTY	3 YEARS	3 YEARS	3 YEARS



INSTALLATION METHODS:

Surface Mount

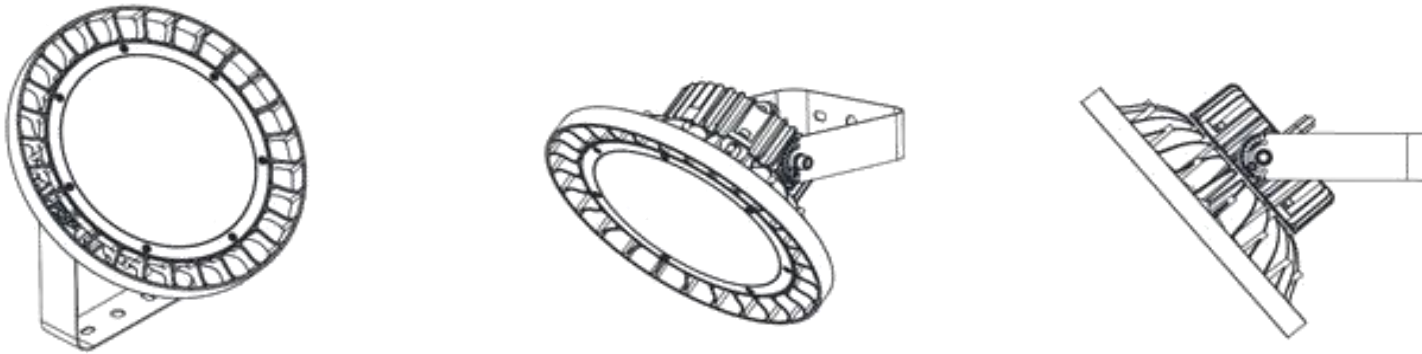

Chain Mount

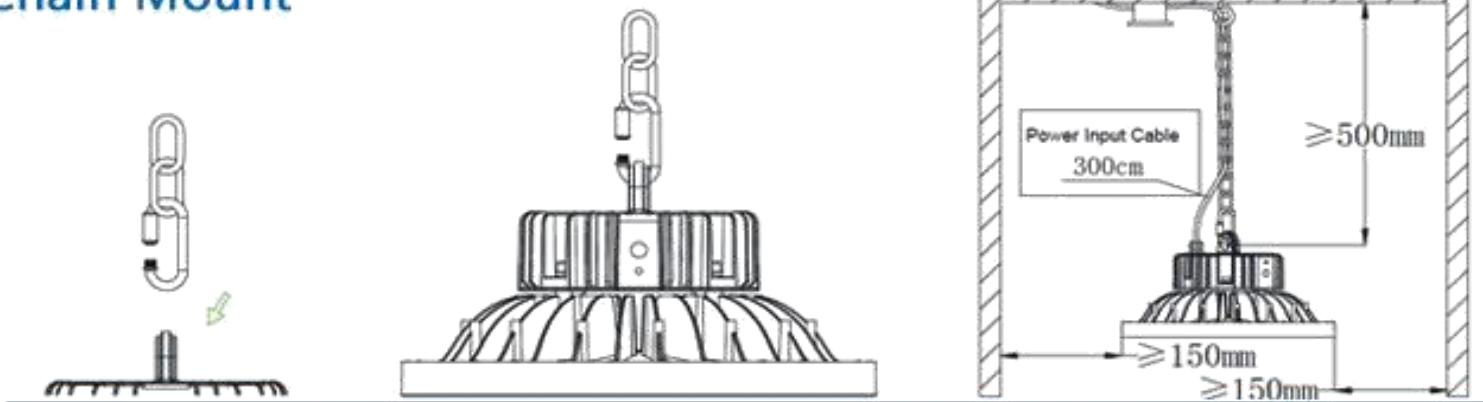

Pole Mount

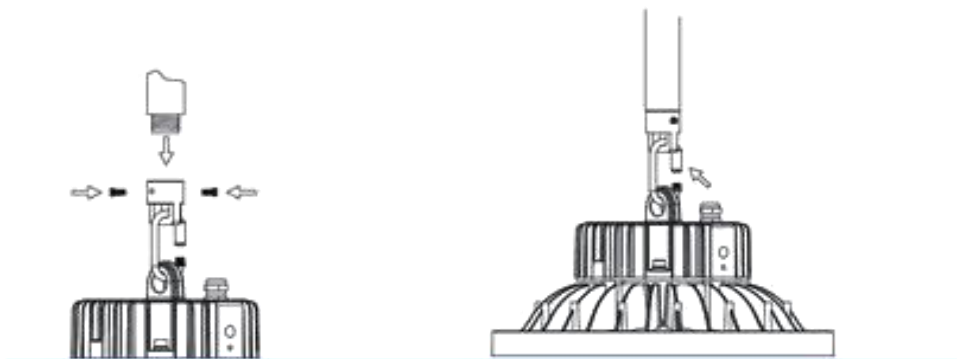



PRODUCT CHARACTERISTIC:

- Beam angle: 120 degrees
- It's major to replace the 200Watt MH/HID/HPS/CFL
- Precision Die Cast Aluminum Housing
- Fade Resistant Powder Coat Finish
- Energy saving up to 70%-80%
- Wide colour availability in degrees
- 50,000 hours, 3 Years Warranty
- It is an ideal replacement for Induction lamp, metal halide or HID lamp
- Wireless Dimming Controlling LED Lighting System Optional

APPLICATION:

Industrial/warehouse/commercial lighting applications, parking garage lighting, Park lighting, Ball Park lighting, Residential areas lighting, Gas Station Road Security Area light, Stadium lighting, cowshed lighting, Gym etc.

