

LJ SOLAR FLOOD LIGHT





PRODUCT PICTURE:



PRODUCT DIMENSION IMAGE:

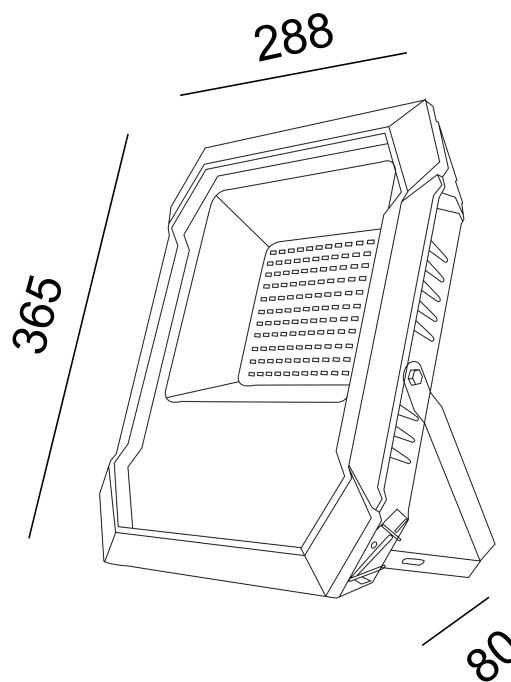
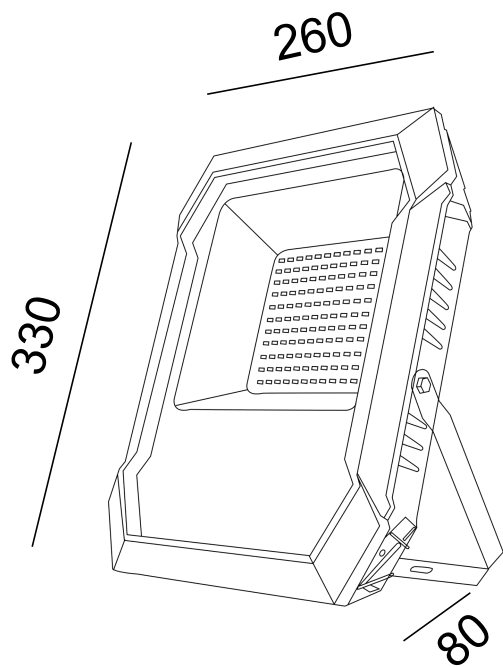



PRODUCT TECHNICAL PARAMETERS

MODEL NO.	LJTYNTGD-200	LJTYNTGD-300
LAMP POWER	200W	300W
SOLAR PANEL	POLYCRYSTALLINE SILICON 6V/20W	POLYCRYSTALLINE SILICON 6V/25W
SOLAR PANEL DIMENSION(MM)	350*450	350*530
BATTERY	LITHIUM IRON PHOSPHATE 18AH	LITHIUM IRON PHOSPHATE 24AH
LEDs	5730	5730
LIGHTING TIME	10-12 HOURS/DAY	10-12 HOURS/DAY
WORKING	INTELLIGENT LIGHT CONTROL + REMOTE CONTROL	INTELLIGENT LIGHT CONTROL + REMOTE CONTROL
CCT	2700-6500K	2700-6500K
LUMENS	1700LM	2500LM
CRI	>80	>80
HOUSING MATERIAL	ABS	ABS
PRODUCT DIMENSION (MM)	260*330*80	288*365*80
IP RATING	IP65	IP65
WARRANTY	3 YEARS	3 YEARS



PRODUCT CHARACTERISTIC:

- ◆ Utilized high brightness LEDs, delivers bright, uniform light
- ◆ Air convection for heat dissipation, high performance with low cost products
- ◆ Long 50,000 hour rated life reduces maintenance and replacement costs
- ◆ DS floodlight comes with adjustable metal bracket, you can easily install it on the ceiling, walls, ground and other locations by adjusting the different angles, to meet your different needs

APPLICATION:

Buildings, Outdoor Advertising Signs, Landscape, Gardens, and so on.

